

## Electric Powertrain

# 14Xe AXLE ELECTRIC POWERTRAIN OPERATOR MANUAL

## Hazard Alert Messages

Read and observe all hazard alert messages in this publication.

### HIGH-VOLTAGE DANGER

Indicates imminent high-voltage danger. Failure to follow this instruction will result in death or serious injury.

### DANGER

Indicates imminent danger. Failure to follow this instruction will result in death or serious injury.

### WARNING

Indicates a possibly impending danger. Failure to follow this instruction can result in death or serious injury.

### CAUTION

Indicates a hazardous situation or unsafe practice which, if not avoided, could result in injury or damage to components.

## How to Obtain Additional Maintenance, Service and Product Information

For service and maintenance information, refer to Maintenance Manual MM-2120, Meritor 14Xe Axle Powertrain; Maintenance Manual MM-0409, Wheel-End Components; and Maintenance Manual 1, Preventive Maintenance. To access these publications, visit Literature on Demand at [meritor.com](http://meritor.com).

For additional assistance, contact the Meritor OnTrac™ Customer Service Center at 866-668-7221 (US and Canada) between 7:30 AM and 10:00 PM ET Monday through Friday, and between 9:00 AM and 6:00 PM ET on Saturday; 001-800-889-1834 (Mexico); or visit our website: [www.meritor.com/warranty#OnTracSC](http://www.meritor.com/warranty#OnTracSC).

## Safety Precautions

Observe the following precautions when operating or working on a vehicle equipped with a Meritor 14Xe axle powertrain:

### ELECTRIC VEHICLE NOTICE

Vehicles equipped with the Meritor 14Xe axle electric powertrain utilize high voltage to power the vehicle. Working on an electric vehicle poses additional hazards beyond service of a conventional vehicle. It is important to carefully read, understand, and follow all directives presented in this publication to ensure safety.

### HIGH-VOLTAGE DANGER

- Vehicles equipped with the Meritor ePowertrain utilize a high-voltage electrical system capable of producing lethal levels of voltage. Contact with the high-voltage electrical system and components including the powertrain, cables and battery packs can result in electric shock, burns or even death. Do not touch any part of the high-voltage electrical system and components for any reason. Use caution at all times and follow all instructions in this publication as directed to avoid injury or death.
- Service of an electric vehicle may be performed ONLY by an OEM-trained, high-voltage technician who is qualified to service electric vehicles. Attempting service or repairs without the proper training, tools and equipment can cause serious injury or death, damage to the vehicle and an unsafe condition for the operator.
- Before performing any procedures on the vehicle, carefully read and understand all instructions and hazard alert messages in this publication. Failure to follow procedures and alerts as directed can result in death, serious injury and damage to components.

cont'd

## ⚡ HIGH-VOLTAGE DANGER

cont'd

- Do not attempt to diagnose or correct vehicle issues on your own. Attempting to repair or service an electric vehicle without the proper training, tools and equipment can result in serious personal injury or even death. Contact Meritor for assistance.
- If any issues involving the high-voltage electrical system are discovered, do not drive the vehicle. Death, serious personal injury and damage to components can result.
- Do not attempt to modify this vehicle in any way. Any modification can affect the high-voltage electrical system, resulting in electric shock, burns or even death, and will void the warranty.

## ⚠ DANGER

Park the vehicle on a level surface. Block the wheels to prevent the vehicle from moving. Support the vehicle with safety stands. NEVER work under a vehicle supported only by jacks. Jacks can slip and fall over. Failure to use safety stands can result in death or serious personal injury and damage to components.

## ⚠ WARNING

This product contains a chemical known to the State of California to cause cancer, birth defects or other reproductive harm.

## ⚠ CAUTION

Changes, modifications, or repairs to this product by parties other than an authorized service provider could void the product warranty.

## Description

The Meritor 14Xe ePowertrain is an electric motive system designed for medium- or heavy-duty electric vehicles. The system consists of a 14Xe axle assembly equipped with a hypoid gear differential carrier, integrated electric traction motor and 2-speed transmission. Also included are an inverter and powertrain control module (PCM) controlled via CAN communications. Figure 1.

The axle may be equipped with 1:1 or 2:1 wheel-end assemblies and utilize Meritor drum or air disc brakes.

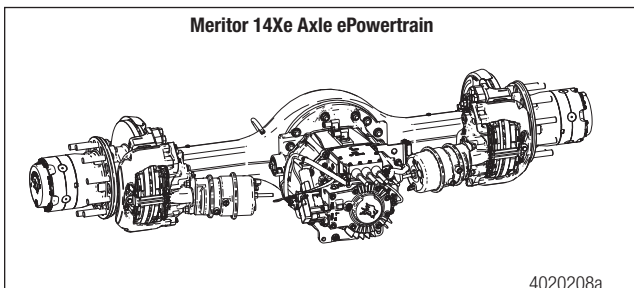

Figure 1

## Driver Controlled Differential Lock Option

The powertrain assembly may be equipped with an optional driver controlled differential lock (DCDL). Refer to the OEM vehicle specifications to determine if the axle is equipped with this option.

The DCDL is operated by an air-actuated shift unit located on the carrier.

- When the differential lock is activated, the shift collar moves along the splines of the axle shaft toward the differential case.
- When the collar engages with the clutch teeth on the differential case, the axle shaft and the differential assembly lock together.
- When the carrier operates with the DCDL in the locked position, there is no differential action between the wheels.
- When the carrier is operated in the unlocked position, there is normal differential action between the wheels at all times.
- For additional DCDL information, refer to Technical Bulletin TP-9579, Driver Instruction Kit. To obtain this publication, visit Literature on Demand at meritor.com.

**NOTE:** If the axle is equipped with a DCDL, the DCDL must be locked in the engaged position to remove/install axle shafts for towing. Refer to the DCDL steps in the Towing procedure for more information.

## 14Xe Axle Powertrain Requirements

The 14Xe axle powertrain has unique requirements for cleaning, towing and maintenance that differ from the standard Meritor 14X axle. It is important to follow the requirements presented in this publication to prevent component damage and ensure safety.

## Pressure Washing

### ⚡ HIGH-VOLTAGE DANGER

Never pressure wash any part of the high-voltage electrical system, electric powertrain or components. Extreme water pressure can damage electrical components. Death or serious personal injury can result.

## Towing

Follow the procedures provided in this publication to prepare the axle for towing and return the axle to service after towing. These instructions supersede all other towing instructions that may appear in other Meritor publications. For additional information regarding vehicle towing, refer to the OEM.

### Avoid High-Voltage Components and Cables

If the vehicle must be towed, inform the tow truck operator that chains or straps are not to be attached to, or placed over, high-voltage components or cables. The high-voltage cables can be identified by the bright orange-colored loom.

## ⚡ HIGH-VOLTAGE DANGER

When towing, never place chains or straps on or across any high-voltage components or orange cables. Inform the tow truck operator that chains or straps are not to be attached to, or placed over, high-voltage components or cables. The high-voltage cables can be identified by the bright orange-colored loom. Damage, personal injury or death can result.

### Vehicle Must Be In NEUTRAL

Vehicles equipped with the ePowertrain must only be towed in Neutral position. Never tow the vehicle in gear. If it is not possible to shift the vehicle into Neutral or confirm that it is in Neutral prior to towing, the vehicle must be transported using a flatbed truck.

## ⚠ CAUTION

Always shift the vehicle into Neutral and confirm it is Neutral position before towing. Never tow the vehicle in gear. If it is not possible to shift the vehicle into Neutral or confirm that it is in Neutral position, the vehicle must be transported using a flatbed truck. Failure to tow the vehicle in Neutral position can result in damage to the inverter, motor, and transmission that may be unreparable.

### Axle Shafts Must Be Removed

The axle shafts must be removed in order to tow the vehicle. Axle shaft removal protects the hypoid pinion from damage that can occur when running at higher speeds with inadequate lubrication.

**NOTE:** Towing angles can also potentially impede lubrication distribution in the axle.

### Pre-Towing Procedure

1. Park the vehicle on a level surface. Set the parking brake. Block the wheels to prevent the vehicle from moving.
2. If the axle is equipped with a DCDL, the DCDL must be locked in the engaged position to allow removal of the axle shafts. A quick way to determine if the axle is equipped with DCDL is to check if an electrical connector is installed for the DCDL switch. Figure 2.

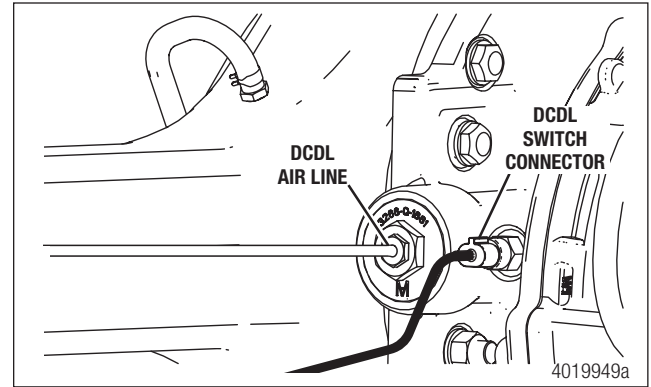

Figure 2

To lock the DCDL, apply air to the shift assembly fitting or remove the air line from the fitting and install a manual caging bolt. Any M10 x 1.5 x 30 bolt can be used as a caging bolt. Figure 3.

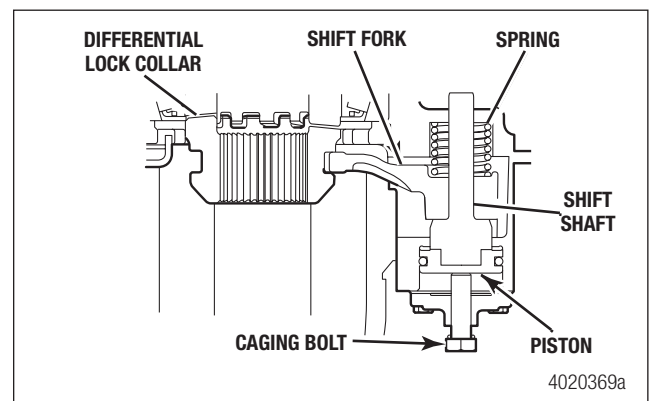

Figure 3

3. Remove both axle shafts from the axle(s) that will remain on the road when the vehicle is transported. The axle will have either a standard 1:1 or 2:1 hub reduction wheel-end assembly. Use the appropriate procedure as follows to remove the axle shafts from the wheel ends.

### For Standard 1:1 Wheel-End Assemblies

- a. Place a container under the wheel end to catch lubricant as it drains from the hub.
- b. If the wheel end is equipped with a fill/drain plug, rotate the wheel end so the plug is at the 6 o'clock position. Remove the plug and allow the lubricant to drain. Reinstall the plug and tighten to 26±3 lb-ft (35±4 Nm).
- c. Remove the eight nuts and washers from the axle shaft. Figure 4.

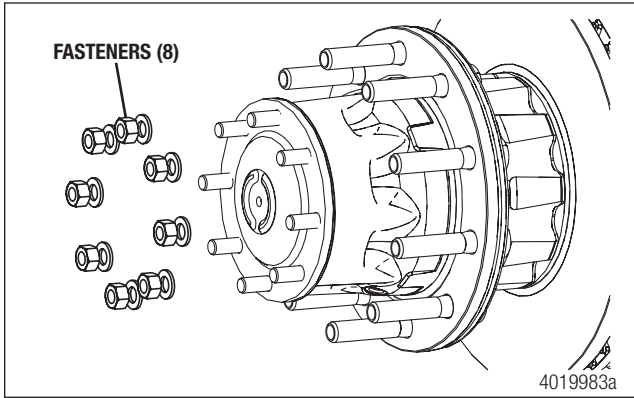

Figure 4

- d. Separate, but do not remove, the axle shaft from the hub. Allow the lubricant to drain.
- e. Remove the axle shaft from the hub and axle housing. Label the location of the axle shafts (left or right side) so they can be reinstalled in the same hub during reassembly. Store the axle shafts in a clean, protected location that will keep them free of dirt and other contaminants. Figure 5.

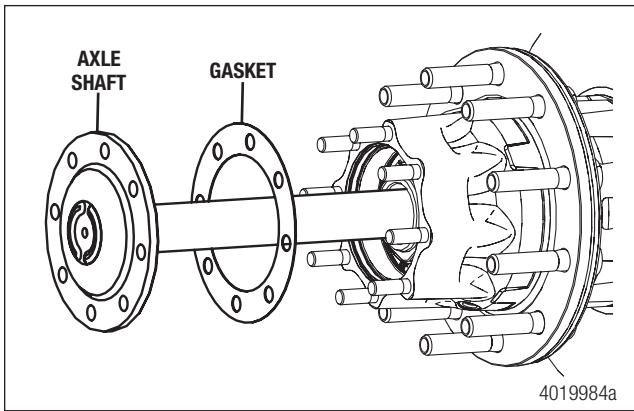

Figure 5

- f. Install a cover over the open end of each hub where an axle shaft was removed. This will prevent dirt from entering the bearing cavity and loss of lubricant.

### For 2:1 Hub Reduction Wheel-End Assemblies

- a. Rotate the wheel end so the drain/fill plug is at the 6 o'clock position. Remove the drain/fill plug and drain the lubricant into a container. Clean the drain plug of debris and reinstall it in the wheel end. Figure 6.

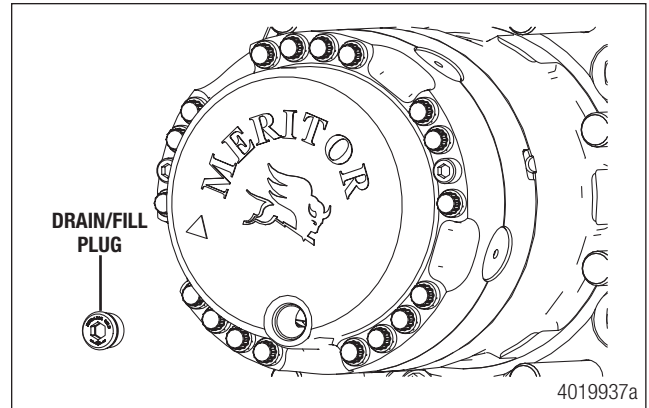

Figure 6

- b. Remove the 18, M12 X 1.75-6g fasteners from the hub reduction wheel-end assembly using a 12-point socket. Do not remove the socket-head bolts. Figure 7.

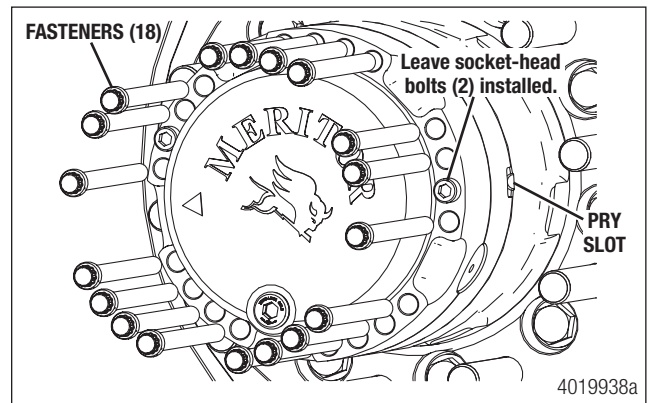

Figure 7

### ⚠ CAUTION

If using a pry tool to loosen the hub, use care to avoid scratching the hub mounting surface.

- c. Remove the hub reduction wheel-end assembly from the hub. If necessary, insert a pry tool in the slot and loosen the assembly from the hub. Figure 8.

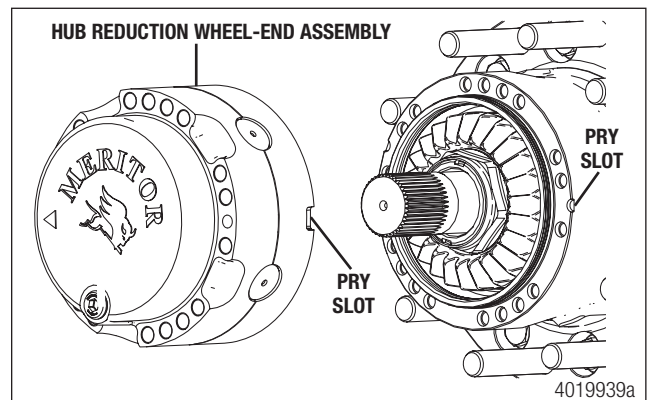
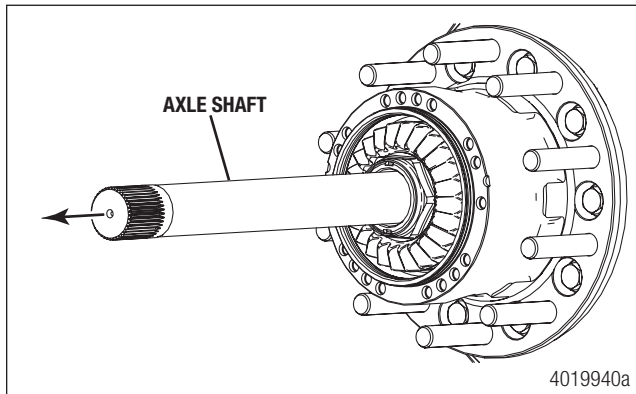

Figure 8

- d. Pull the axle shafts out of the hub and axle housing. Label the location of the axle shafts (left or right side) so they can be reinstalled in the same hub during reassembly. Also label which end of the shaft goes into the carrier. Store the axle shafts in a clean, protected location that will keep them free of dirt and other contaminants. Figure 9.



**Figure 9**

- e. Reinstall the hub reduction wheel-end assemblies with the 18 fasteners in each hub. This will keep all parts together during transport as well as prevent dirt from entering the bearing cavity and loss of lubricant.

**Proceed with Step 4 once the axle shafts are removed from the wheel ends.**

**NOTE:** If an air supply will be used for the brake system of the transported vehicle, continue with Step 4 and Step 5, otherwise continue with Step 6.

4. Connect an auxiliary air supply to the brake system of the vehicle that is being transported. Before moving the vehicle, charge the brake system with the correct amount of air pressure to operate the brakes. Refer to the instructions supplied by the vehicle manufacturer for procedures and specifications. If an auxiliary air supply is not used, continue with Step 6.
5. When the correct amount of air pressure is in the brake system, release the parking brakes of the vehicle that is being transported. Step 6 is not required.
6. If there are spring or parking brakes on the axle(s) that will remain on the road when the vehicle is transported, and they cannot be released by air pressure, manually compress and lock each spring so that the brakes are released. Refer to the manufacturer's instructions.

## ⚠ CAUTION

Always shift the vehicle into Neutral and confirm it is in Neutral position before towing. Never tow the vehicle in gear. If it is not possible to shift the vehicle into Neutral or confirm that it is in Neutral position, the vehicle must be transported using a flatbed truck. Failure to tow the vehicle in Neutral position can result in damage to the inverter, motor, and transmission that may be unreparable.

7. Shift the vehicle into Neutral. The vehicle is now ready to be towed.

### Post-Towing Procedure

1. If an auxiliary air supply was used, apply the vehicle parking brakes using the switch inside the cab of the vehicle. If an auxiliary air supply was not used, begin with Step 2.
2. Apply the vehicle spring or parking brakes by manually releasing each spring that was compressed before transporting started. Refer to the manufacturer's instructions.
3. Disconnect the auxiliary air supply, if used, from the brake system of the vehicle that was transported. Connect the vehicle's air supply to the brake system.
4. Reinstall the axle shafts using the appropriate procedures as follows. Ensure the axle shafts are returned to the same hubs from which they were removed.

### Standard 1:1 Wheel-End Assembly

- a. Remove the covers from the hubs. Clean the axle shaft mounting surface on the hub. Make sure it is free of debris and oil.
- b. Install a new gasket over the studs and flat against the hub. Figure 10.

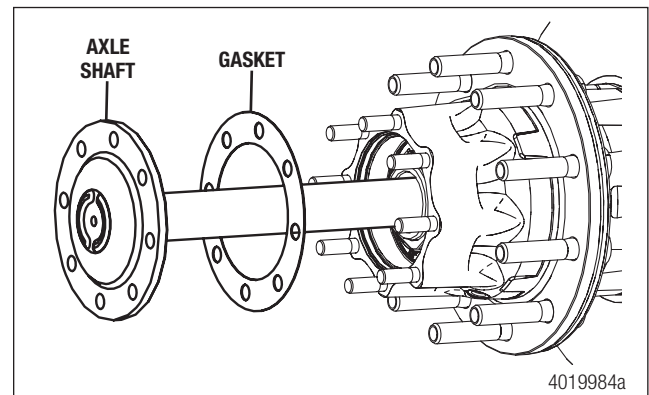

**Figure 10**

- c. Clean off any debris and apply a coat of axle oil to the axle shafts.



d. If the axle is equipped with a DCDL, the DCDL must be locked in the engaged position to allow installation of the double-splined axle shaft. To lock the DCDL, apply air to the shift assembly fitting or install a manual caging bolt. Any M10 x 1.5 x 30 bolt can be used as a caging bolt. Figure 11.

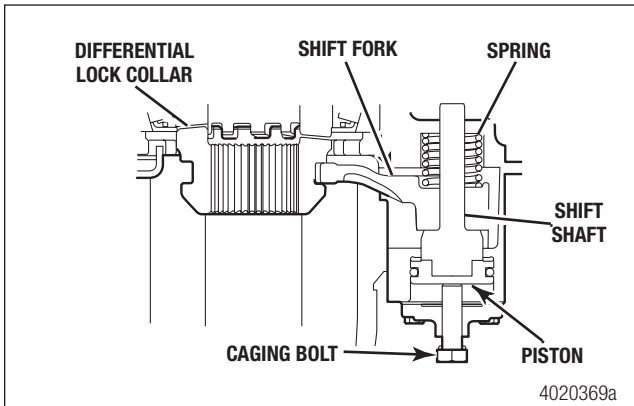
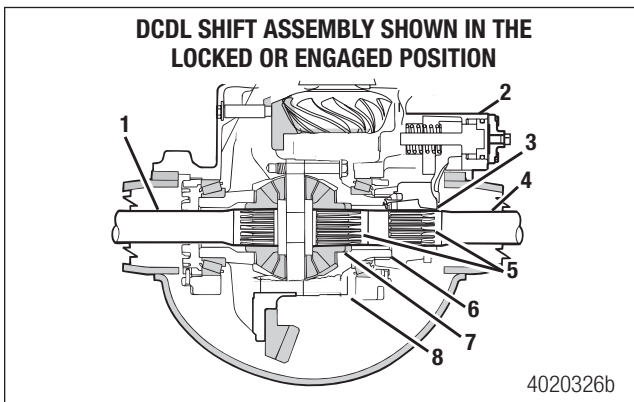

Figure 11

e. Install the axle shafts through the hub and axle housing, and engage the splines in the carrier. Make sure the axle shafts are returned to the correct hubs (left or right side) from which they were removed.

If the axle has a DCDL, install the axle shaft with the double row of splines first. Once the double-splined shaft is installed, remove the shop air line or caging bolt from the fitting and reinstall the air line to the fitting. Continue installation of the remaining axle shaft. Figure 12.



- 1 ROADSIDE, AXLE SHAFT WITH SINGLE-SPLINED END
- 2 SHIFT ASSEMBLY
- 3 SHIFT COLLAR
- 4 CURBSIDE, AXLE SHAFT WITH DOUBLE-SPLINED END
- 5 DOUBLE ROW OF SPLINES
- 6 SHIFT COLLAR AND DIFFERENTIAL CASE SPLINES LOCKED
- 7 SIDE GEAR
- 8 DIFFERENTIAL CASE

Figure 12

f. If the axle shaft utilizes lock nuts, install eight new lock nuts and washers. If the axle shaft utilizes tapered dowels and non-locking nuts, apply Loctite® 242 threadlocker to the nuts. Install the eight nuts and washers. Tighten fasteners to the torque specified in following table. Figure 13.

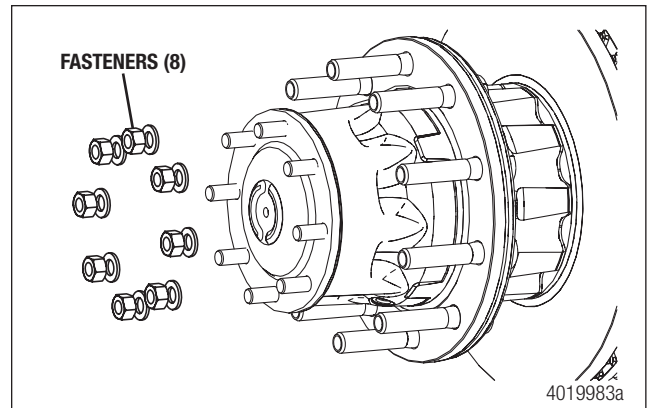

Figure 13

### Axle Shaft Torque Specifications

Fastener	Size	Torque* Lb-Ft (Nm)
Axle Shaft-to-Flange Lock Nuts	0.438"-20	40-65 (54-88)
	0.50"-20	65-100 (88-136)
	0.562"-18	100-145 (136-197)
	0.625"-18	130-190 (176-258)
Axle Shaft-to-Flange Plain Non-Locking Nuts	0.438"-20	50-75 (68-102)
	0.50"-20	75-115 (102-156)
	0.562"-18	110-165 (149-224)
	0.625"-18	150-230 (203-312)

\*Target the middle torque in the range shown.

g. If the hub is equipped with a fill plug, rotate the wheel end so the fill plug is facing up. Remove the plug. Add 0.79 quart (0.75 liter) of 75W-90 full-synthetic oil to the hub. Figure 14.

**NOTE:** If the hub is not equipped with a fill plug, refer to Maintenance Manual 1, Preventive Maintenance and Lubrication, for hub fill and axle tilting instructions.

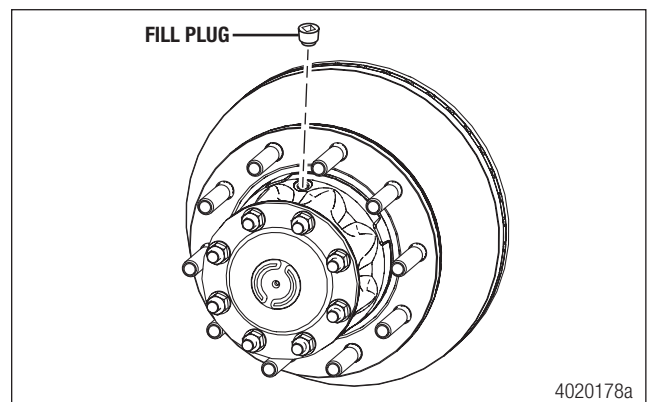

Figure 14

h. Install and tighten the drain/fill plug to 15-25 lb-ft (20-34 Nm).

### 2:1 Hub Reduction Wheel-End Assembly

a. Remove the 18 fasteners and the hub reduction wheel-end assembly from each hub.

- b. Clean the mounting surfaces on the hub and hub reduction assembly. Ensure they are free of debris and oil.
- c. Clean off any debris and apply a coat of oil to the axle shafts.
- d. If the axle is equipped with a DCDL, the DCDL must be locked in the engaged position to allow installation of the double-splined axle shaft. To lock the DCDL, apply air to the shift assembly fitting or install a manual caging bolt. Any M10 x 1.5 x 30 bolt can be used as a caging bolt. Figure 11.
- e. Install the axle shafts through the hub and axle housing, and engage the splines in the carrier. Make sure the axle shafts are installed into the correct hub (left or right) and the correct end of the shaft is inserted into the carrier. Figure 15.

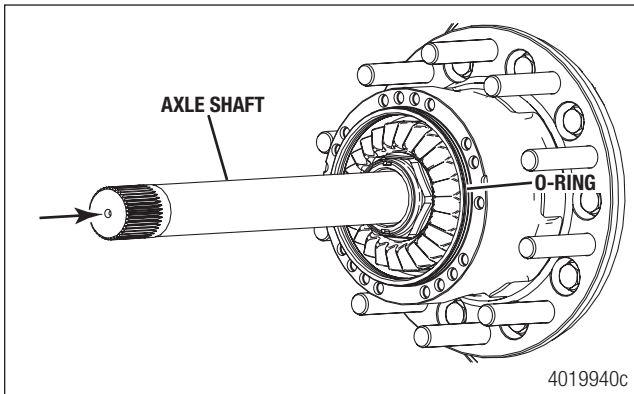

Figure 15

If the axle has a DCDL, install the axle shaft with the double row of splines first. Once the double-splined shaft is installed, remove the shop air line or caging bolt from the fitting and reinstall the air line to the fitting. Continue installation of the remaining axle shaft. Figure 12.

- f. Ensure the large O-ring on the hub is free of debris, lubricated and properly seated in the O-ring groove. Figure 15.
- g. Align the pry slot on the hub reduction wheel-end assembly with the pry slot on the hub and rotor assembly. Place the hub reduction assembly on the hub and rotor assembly and align the bolt holes. Figure 16.

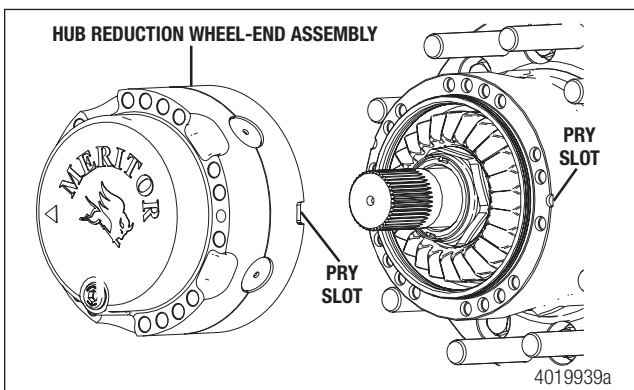

Figure 16

- h. Install the 18, M12 X 1.75-6g fasteners on the hub reduction wheel-end assembly and tighten to 74-96 lb-ft (100-130 Nm) using a 12-point socket. Figure 17.

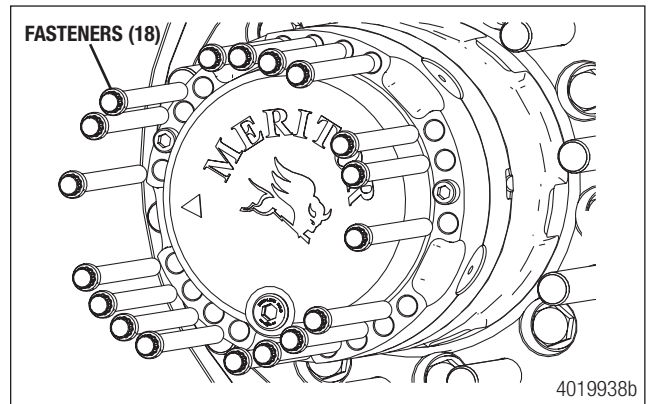

Figure 17

- i. Rotate the wheel end so the arrow on the wheel end cover points towards the ground (6 o'clock position). The drain/fill plug will be approximately at the 4 o'clock position. Figure 18.

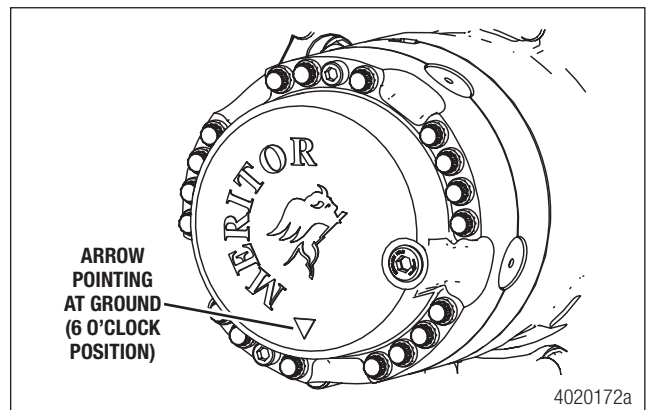

Figure 18

- j. Remove the drain/fill plug. Add 75W-90 full-synthetic oil to the wheel end until the level reaches the bottom of the plug hole, approximately 1.06 quarts (1 liter). Install the drain/fill plug and tighten to 26±3 lb-ft (35±4 Nm). Figure 19.

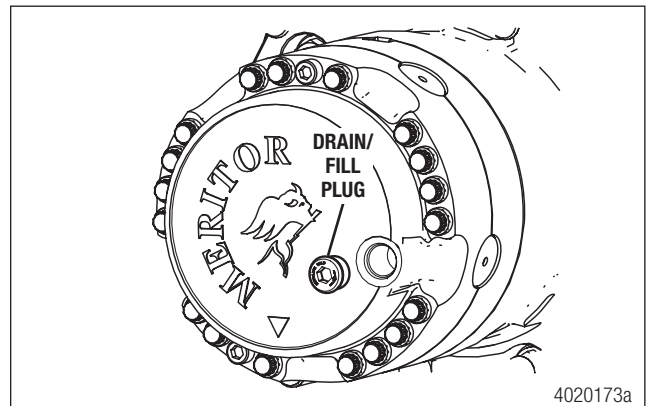

Figure 19

# Maintenance

## Lubrication Schedule

### Oil Change Intervals for 14Xe Axle and Wheel Ends

Operation	Frequency
Initial oil change	2,500 miles (4023 km)
Check oil level	Every 25,000 miles (40 000 km), or the fleet maintenance interval, whichever comes first
Change oil	Every 50,000 miles (80 467 km), or annually, whichever comes first

Refer to Maintenance Manual MM-2120 for complete oil check and change instructions.

## Lubricant Specifications

75W-90 Full-synthetic oil is approved for use in the 14Xe axle.

Meritor Spec.	Grade	Cross Reference	Min. Outside Temp.	Min. Outside Temp.
O-76-E	Hypoid Gear Oil	GL-5, S.A.E. 75W/90	-40°F (-40°C)	*

\*There is no upper limit on these outside temperatures, but the axle sump temperature must never exceed 250°F (+121°C).

## Lubricant Temperatures

### CAUTION

Meritor axles may operate with an oil temperature above 250°F (121°C). However, if the oil temperature reaches 300°F (148°C), stop the vehicle immediately. Check for the cause of overheating to prevent damage to components.

Meritor axles may operate with an oil temperature above 250°F (121°C). However, if the oil temperature reaches 300°F (148°C), stop the vehicle immediately and check for the cause of overheating. Oil temperatures at this range should only occur in linehaul or utility applications that operate under high speed for long periods of time.

**NOTE:** If the axle reaches a temperature over a specified limit, it will derate power until the temperature is back within the specified limit.



**Meritor Heavy Vehicle Systems, LLC**  
2135 West Maple Road  
Troy, MI 48084 USA  
866-OnTrac1 (668-7221)  
meritor.com

Information contained in this publication was in effect at the time the publication was approved for printing and is subject to change without notice or liability. Meritor Heavy Vehicle Systems, LLC, reserves the right to revise the information presented or to discontinue the production of parts described at any time.

Copyright 2022  
Meritor Inc.  
All Rights Reserved

Printed in USA

TP-20142  
Issued 03-22  
(16579)